

40V, 2MHz Rail-to-Rail Output High Precision Operational Amplifier

1 FEATURES

- **Low Offset Voltage: $\pm 2\mu\text{V}$**
- **Low Bias Current**
- **Gain Bandwidth Product: 2MHz**
- **Rail-to-Rail Output**
- **High Slew Rate: $1.5\text{V}/\mu\text{s}$**
- **Low Quiescent Current: 0.92mA (TYP)**
- **Supply Voltage Range: 3.2V to 40V**
- **Over-Temperature Protection**
- **Low Noise: $20\text{nV}/\sqrt{\text{Hz}}$ at 1kHz**
- **Differential Input Voltage Up to Supply Rail, can Work as Comparator**
- **Extended Temperature: -40°C to 125°C**
- **Micro SIZE PACKAGES: SOT23-5, SOP8, MSOP8**

2 APPLICATIONS

- **Sensors**
- **Photodiode Amplification**
- **Active Filters**
- **Test Equipment**
- **Driving A/D Converters**
- **Industrial Control**

3 DESCRIPTIONS

The RSOP07 is a low noise, low offset voltage and high voltage operational amplifier, which can be designed into a wide range of applications. The RSOP07 has a gain-bandwidth product of 2MHz, a slew rate of $1.5\text{V}/\mu\text{s}$ and a quiescent current of 0.92mA at wide power supply range.

The RSOP07 is designed to provide optimal performance in low noise systems. It provides rail-to rail output swing into heavy loads.

The RSOP07 has over-temperature protection feature to guarantee the chip safe. The output of RSOP07 will enter high impedance when die temperature reach around 170°C and will recover the function when the die temperature down to around 150°C .

The RSOP07 is available in Green SOT23-5, SOP8, MSOP8 packages. It operates over an ambient temperature range of -40°C to 125°C under single power supplies of 3.2V to 40V or dual power supplies of $\pm 1.6\text{V}$ to $\pm 20\text{V}$.

Device Information ⁽¹⁾

PART NUMBER	PACKAGE	BODY SIZE(NOM)
RSOP07-1	SOT23-5	1.60mm × 2.92mm
	SOP8	4.90mm × 3.90mm
RSOP07-2	SOP8	4.90mm × 3.90mm
	MSOP8	3.00mm × 3.00mm

(1) For all available packages, see the orderable addendum at the end of the data sheet.

Table of Contents

1 FEATURES	1
2 APPLICATIONS	1
3 DESCRIPTIONS	1
4 REVISION HISTORY	3
5 PACKAGE/ORDERING INFORMATION ⁽¹⁾	4
6 PIN CONFIGURATION AND FUNCTIONS (TOP VIEW)	5
7 SPECIFICATIONS	6
7.1 Absolute Maximum Ratings	6
7.2 ESD Ratings	6
7.3 Recommended Operating Conditions	6
7.4 Electrical Characteristics	7
7.5 Typical Characteristics	9
8 PACKAGE OUTLINE DIMENSIONS	13
9 TAPE AND REEL INFORMATION	16

Preliminary version

4 REVISION HISTORY

Note: Page numbers for previous revisions may differ from page numbers in the current version.

VERSION	Change Date	Change Item
A.0	2025/12/04	Preliminary version completed
A.0.1	2025/12/19	Update Electrical Characteristics

Preliminary version

5 PACKAGE/ORDERING INFORMATION ⁽¹⁾

Orderable Device	Package Type	Pin	Channel	Op Temp(°C)	Device Marking ⁽²⁾	MSL ⁽³⁾	Package Qty
RSOP07-1XF	SOT23-5	5	1	-40°C ~125°C	OP07-1	MSL1	Tape and Reel,3000
RSOP07-1XK	SOP8	8	1	-40°C ~125°C	RSOP07-1	MSL1	Tape and Reel,4000
RSOP07-2XK	SOP8	8	2	-40°C ~125°C	RSOP07-2	MSL1	Tape and Reel,4000
RSOP07-2XM	MSOP8	8	2	-40°C ~125°C	RSOP07-2	TBD	Tape and Reel,4000

NOTE:

- (1) This information is the most current data available for the designated devices. This data is subject to change without notice and revision of this document. For browser-based versions of this data sheet, refer to the right-hand navigation.
- (2) There may be additional marking, which relates to the lot trace code information (data code and vendor code), the logo or the environmental category on the device.
- (3) Runic classify the MSL level with using the common preconditioning setting in our assembly factory conforming to the JEDEC industrial standard J-STD-20F. Please align with Runic if your end application is quite critical to the preconditioning setting or if you have special requirement.

Preliminary version

6 PIN CONFIGURATION AND FUNCTIONS (TOP VIEW)

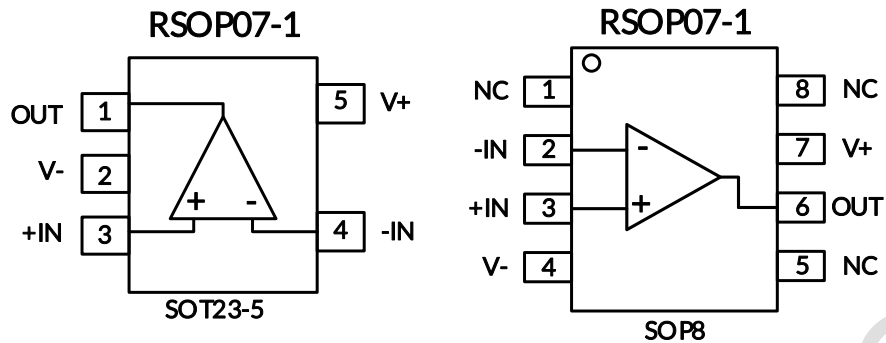

Pin Description

NAME	PIN		I/O ⁽¹⁾	DESCRIPTION
	SOT23-5	SOP8		
OUT	1	6	O	Output
V-	2	4	-	Negative (lowest) power supply
+IN	3	3	I	Positive (noninverting) input
-IN	4	2	I	Negative (inverting) input
V+	5	7	-	Positive (highest) power supply
NC ⁽²⁾	-	1,5,8	-	No internal connection (can be left floating)

(1) I = Input, O = Output.

(2) There is no internal connection. Typically, GND is the recommended connection to a heat spreading plane.

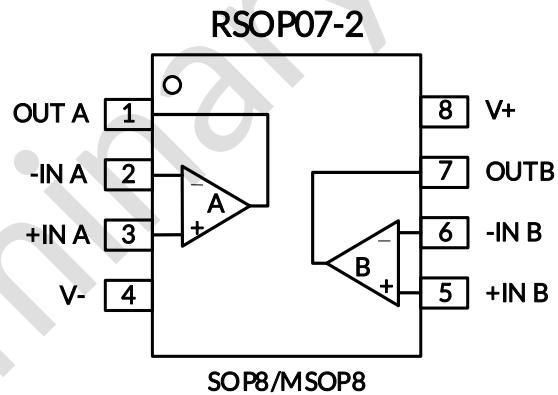

Pin Description

NAME	PIN		I/O ⁽¹⁾	DESCRIPTION
	SOP8/MSOP8			
-INA	2		I	Inverting input, channel A
+INA	3		I	Noninverting input, channel A
-INB	6		I	Inverting input, channel B
+INB	5		I	Noninverting input, channel B
OUTA	1		O	Output, channel A
OUTB	7		O	Output, channel B
V-	4		-	Negative (lowest) power supply
V+	8		-	Positive (highest) power supply

(1) I = Input, O = Output.

7 SPECIFICATIONS

7.1 Absolute Maximum Ratings

Over operating free-air temperature range (unless otherwise noted) ⁽¹⁾

		MIN	MAX	UNIT
Voltage	Supply, $V_S=(V+) - (V-)$		42	V
	Signal input pin ⁽²⁾	(V-) - 0.3	(V+) + 0.3	
	Signal output pin ⁽³⁾	(V-) - 0.3	(V+) + 0.3	
	Differential input voltage	(V-) - (V+)	(V+) - (V-)	
Current	Signal input pin ⁽²⁾	-10	10	mA
	Signal output pin ⁽³⁾	-10	10	mA
	Output short-circuits ⁽⁴⁾	Continuous		
θ_{JA}	Package thermal impedance ⁽⁵⁾	SOT23-5	230	°C/W
		SOP8	110	
		MSOP8	170	
Temperature	Operating range, T_A	-40	125	°C
	Junction, T_J ⁽⁶⁾	-40	150	
	Storage, T_{stg}	-65	150	
	Lead temperature (Soldering, 10sec)		260	

(1) Stresses above these ratings may cause permanent damage. Exposure to absolute maximum conditions for extended periods may degrade device reliability. These are stress ratings only, and functional operation of the device at these or any other conditions beyond those specified is not implied.

(2) Input terminals are diode-clamped to the power-supply rails. Input signals that can swing more than 0.3V beyond the supply rails should be current-limited to 10mA or less.

(3) Output terminals are diode-clamped to the power-supply rails. Output signals that can swing more than 0.3V beyond the supply rails should be current-limited to ± 10 mA or less.

(4) Short-circuit to ground, one amplifier per package.

(5) The package thermal impedance is calculated in accordance with JESD-51.

(6) The maximum power dissipation is a function of $T_{J(MAX)}$, $R_{\theta JA}$, and T_A . The maximum allowable power dissipation at any ambient temperature is $P_D = (T_{J(MAX)} - T_A) / R_{\theta JA}$. All numbers apply for packages soldered directly onto a PCB.

7.2 ESD Ratings

The following ESD information is provided for handling of ESD-sensitive devices in an ESD protected area only.

			VALUE	UNIT
$V_{(ESD)}$	Electrostatic discharge	Human-Body Model (HBM), EIA/JESD22-a114	± 2000	V
		Charged-Device Model (CDM), ANSI/ESDA/JEDEC JS-002-2025	± 1000	



ESD SENSITIVITY CAUTION

ESD damage can range from subtle performance degradation to complete device failure. Precision integrated circuits may be more susceptible to damage because very small parametric changes could cause the device not to meet its published specifications.

7.3 Recommended Operating Conditions

Over operating free-air temperature range (unless otherwise noted).

		MIN	MAX	UNIT
Supply voltage, $V_S= (V+) - (V-)$	Single-supply	3.2	40	V
	Dual-supply	± 1.6	± 20	

7.4 Electrical Characteristics

At $T_A = +25^\circ\text{C}$, $V_S = 40\text{V}$, $V_{CM} = V_S/2$, $R_L = 10\text{k}\Omega$, Full ⁽⁹⁾ = -40°C to 125°C , unless otherwise noted ⁽¹⁾

PARAMETER	CONDITIONS	T_A	RSOP07			UNIT	
			MIN ⁽²⁾	TYP ⁽³⁾	MAX ⁽²⁾		
POWER SUPPLY							
V_S	Operating Voltage Range	Full	3.2		40	V	
I_Q	Quiescent Current per Amplifier	$V_S = 3.2\text{V}$	25°C		0.72	0.92	mA
			Full			1.05	
		$V_S = 40\text{V}$	25°C		0.92	1.2	
			Full			1.35	
PSRR	Power-Supply Rejection Ratio	$V_S = 3.2\text{V}$ to 40V	25°C	120	135	dB	
			Full	115			
INPUT							
V_{OS}	Input Offset Voltage	$V_S = 3.2\text{V}$, $V_{CM} = 0\text{V}$	25°C	-20	± 2	20	μV
			Full	-50		50	
		$V_S = 40\text{V}$, $V_{CM} = 0\text{V}$	25°C	-20	± 5	20	μV
			Full	-60		60	
$V_{OS} T_C$	Input Offset Voltage Drift	Full		± 0.25		$\mu\text{V}/^\circ\text{C}$	
IB	Input Bias Current ⁽⁴⁾⁽⁵⁾	$V_S = 40\text{V}$, $V_{CM} = 20\text{V}$	25°C	-500	± 50	500	pA
			Full	-5000		5000	
I_{OS}	Input Offset Current ⁽⁴⁾	$V_S = 40\text{V}$, $V_{CM} = 20\text{V}$	25°C		± 100		pA
			Full	-5000		5000	
I_{IN}	Different Input Current	$V_S = 40\text{V}$, $V_{ID} = 40\text{V}$	25°C	-3	0.5	3	μA
C_{IN}	Input Capacitance	Differential Mode	25°C		5		pF
		Common Mode	25°C		3		pF
AOL	Open-loop Voltage Gain	$R_{LOAD} = 10\text{k}\Omega$, $V_{OUT} = -19.5\text{V}$ to 19.5V	25°C	120	140		dB
			Full	115			dB
V_{CM}	Common-Mode Voltage Range	Full	(V-)-0.1		(V+)-1.8	V	
CMRR	Common-Mode Rejection Ratio	$V_{CM} = 0$ to 38.2V	25°C	120	140		dB
			Full	115			
OUTPUT							
V_{OH}	Output Swing from Positive Rail	$R_{LOAD} = 10\text{k}\Omega$ to $V_S/2$	25°C		85	150	mV
V_{OL}	Output Swing from Negative Rail	$R_{LOAD} = 10\text{k}\Omega$ to $V_S/2$	25°C		50	150	mV
I_{SC}	Short-Circuit Current ⁽⁶⁾⁽⁷⁾	Source	25°C	40	60		mA
		Sink	25°C	55	75		
AC Specifications							
SR	Slew Rate ⁽⁸⁾	G=1, 10V Step	25°C		1.5		V/ μs
GBW	Gain-Bandwidth Product		25°C		2		MHz
t_s	Settling Time, 0.1%	G=1, 10V Step	25°C		25		μs
t_{OR}	Overload Recovery Time		25°C		520		ns
PM	Phase Margin	$R_L = 10\text{k}\Omega$, $C_L = 1\text{nF}$	25°C		60		°
GM	Gain Margin	$R_L = 10\text{k}\Omega$, $C_L = 1\text{nF}$	25°C		10		dB

NOISE							
En	Input Voltage Noise	V _S = 5V, f = 0.1Hz to 10Hz	25°C		0.45		μVpp
en	Input Voltage Noise Density ⁽⁴⁾	f = 0.1kHz	25°C		20		nV/√Hz
		f = 1kHz	25°C		20		
		f = 10kHz	25°C		25		
THD+N	Total Harmonic Distortion and Noise	f = 1kHz, G = 1, R _L = 10kΩ, V _{OUT} = 6Vrms			0.0002		%
Thermal Protection							
T _{SHDN}	Thermal Shutdown Temperature				170		°C
ΔT _{SHDN}	Thermal Shutdown Hysteresis				20		

NOTE:

- (1) Electrical table values apply only for factory testing conditions at the temperature indicated. Factory testing conditions result in very limited self-heating of the device.
- (2) Limits are 100% production tested at 25°C. Limits over the operating temperature range are ensured through correlations using statistical quality control (SQC) method.
- (3) Typical values represent the most likely parametric norm as determined at the time of characterization. Actual typical values may vary over time and will also depend on the application and configuration.
- (4) This parameter is ensured by design and/or characterization and is not tested in production.
- (5) Positive current corresponds to current flowing into the device.
- (6) The maximum power dissipation is a function of T_{J(MAX)}, R_{θJA}, and T_A. The maximum allowable power dissipation at any ambient temperature is P_D = (T_{J(MAX)} - T_A) / R_{θJA}. All numbers apply for packages soldered directly onto a PCB.
- (7) Short circuit test is a momentary test.
- (8) Number specified is the slower of positive and negative slew rates.
- (9) Specified by characterization only.

7.5 Typical Characteristics

NOTE: The graphs and tables provided following this note are a statistical summary based on a limited number of samples and are provided for informational purposes only.

At $T_A = +25^\circ\text{C}$, $V_S = \pm 20\text{V}$, $V_{CM} = V_S/2$, $R_L = 10\text{k}\Omega$, unless otherwise specified.

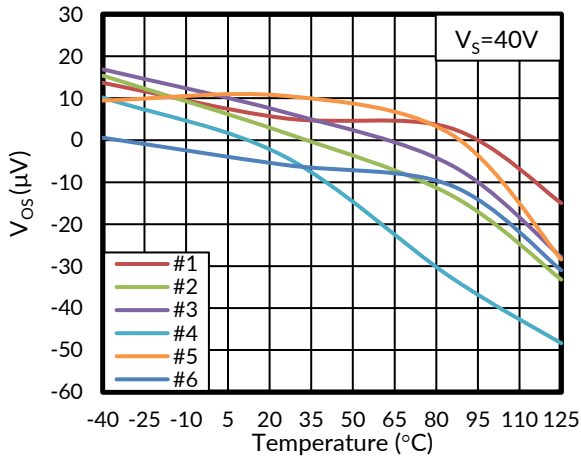

Figure 1. Offset Voltage vs Temperature

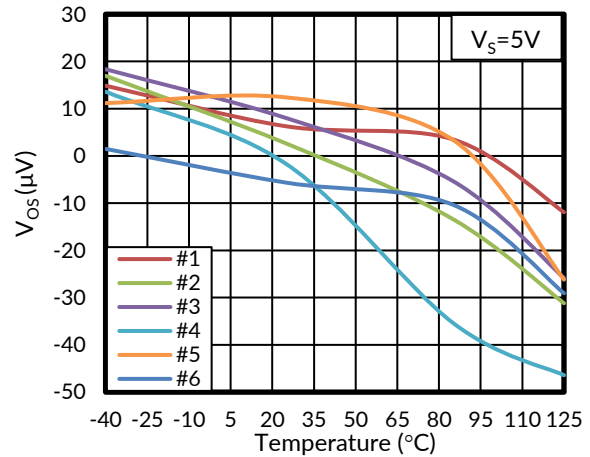

Figure 2. Offset Voltage vs Temperature

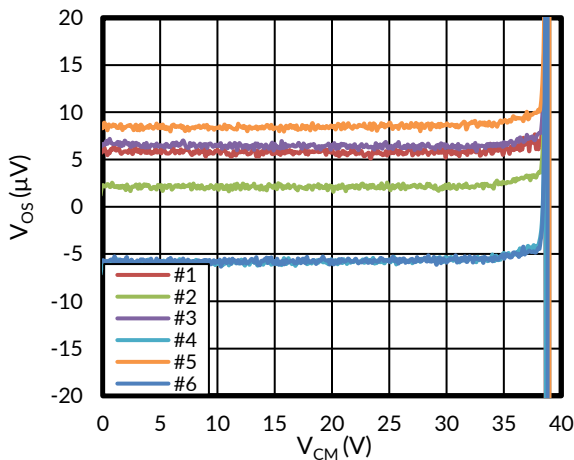

Figure 3. Offset Voltage vs Common Mode Voltage

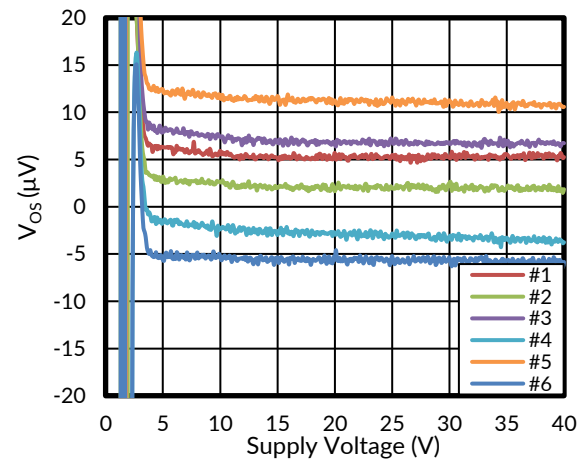

Figure 4. Offset Voltage vs Supply Voltage

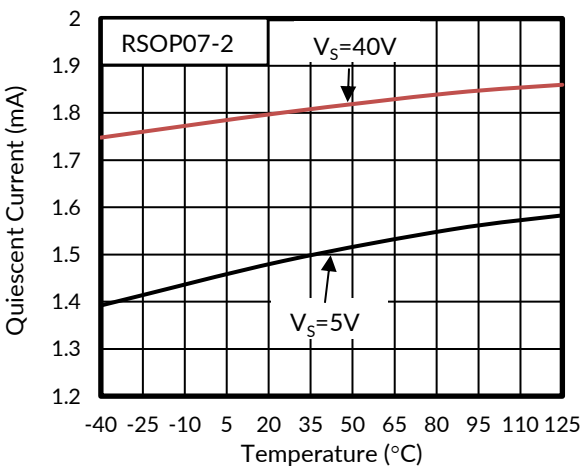

Figure 5. Quiescent Current vs Temperature

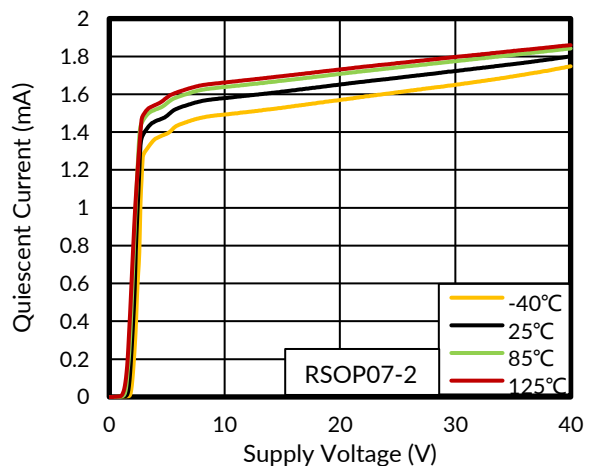

Figure 6. Quiescent Current vs Supply Voltage

Typical Characteristics

NOTE: The graphs and tables provided following this note are a statistical summary based on a limited number of samples and are provided for informational purposes only.

At $T_A = +25^\circ\text{C}$, $V_S = \pm 20\text{V}$, $V_{CM} = V_S/2$, $R_L = 10\text{k}\Omega$, unless otherwise specified.

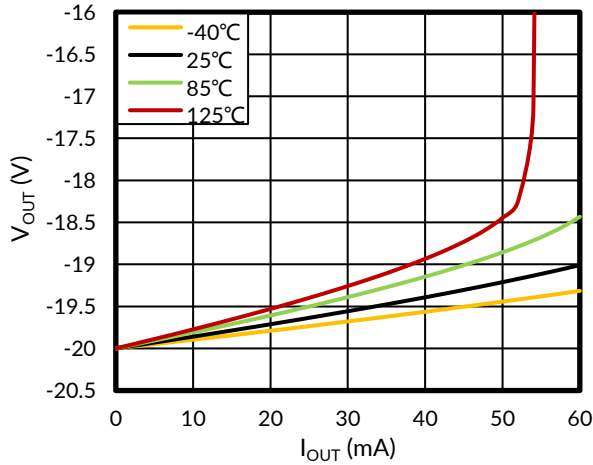

Figure 7. V_{OUT} vs I_{OUT} , Sink

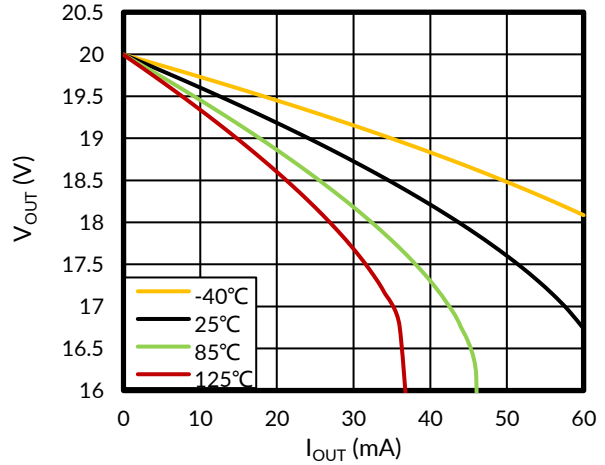

Figure 8. V_{OUT} vs I_{OUT} , Source

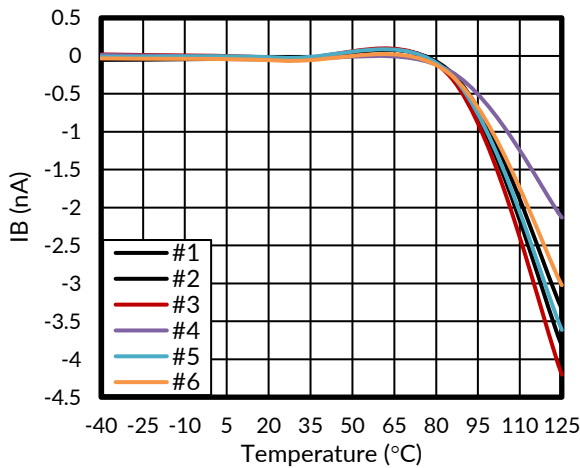

Figure 9. Input Bias Current vs Temperature

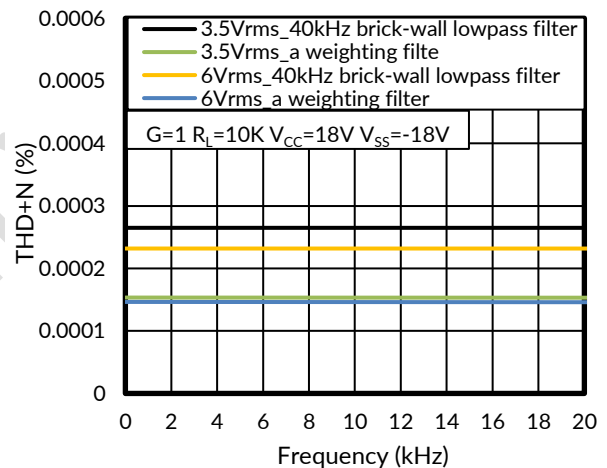

Figure 10. THD+N vs Frequency

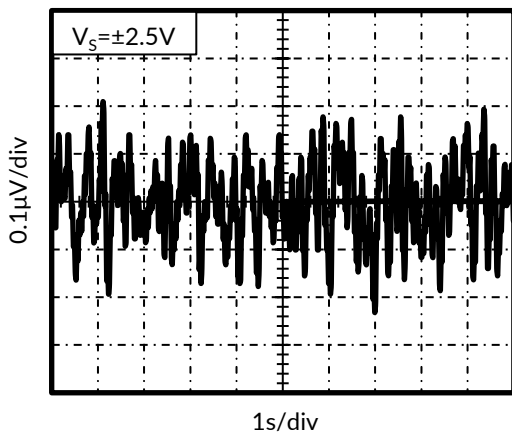

Figure 11. 0.1Hz to 10Hz Input Voltage Noise

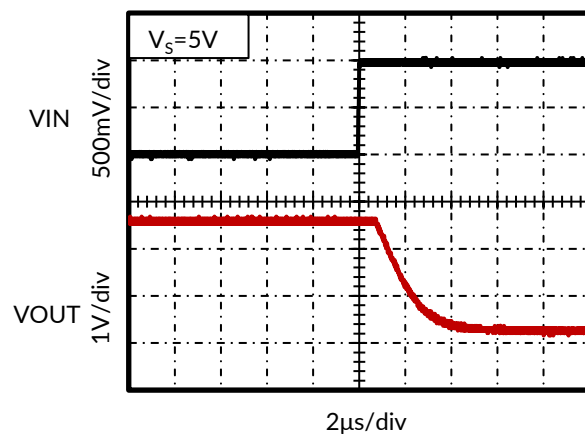

Figure 12. Positive Overload Recovery

Typical Characteristics

NOTE: The graphs and tables provided following this note are a statistical summary based on a limited number of samples and are provided for informational purposes only.

At $T_A = +25^\circ\text{C}$, $V_S = \pm 20\text{V}$, $V_{CM} = V_S/2$, $R_L = 10\text{k}\Omega$, unless otherwise specified.

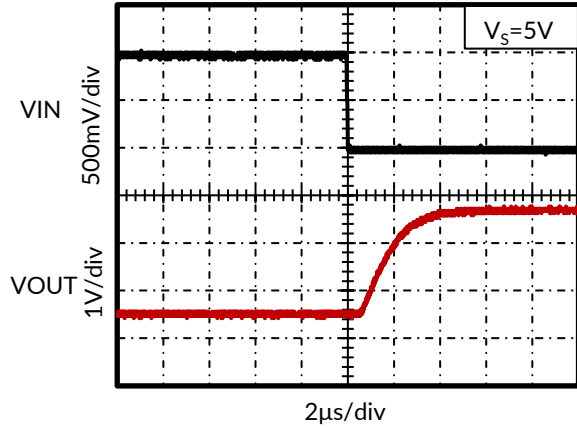

Figure 13. Negative Overload Recovery

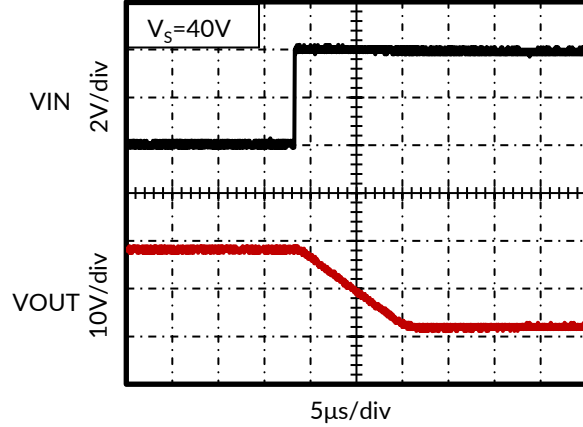

Figure 14. Positive Overload Recovery

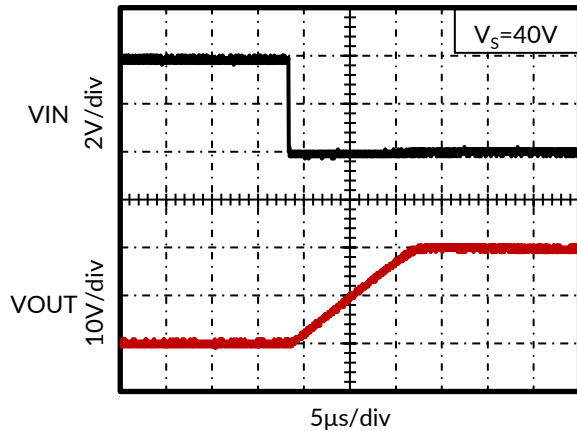

Figure 15. Negative Overload Recovery

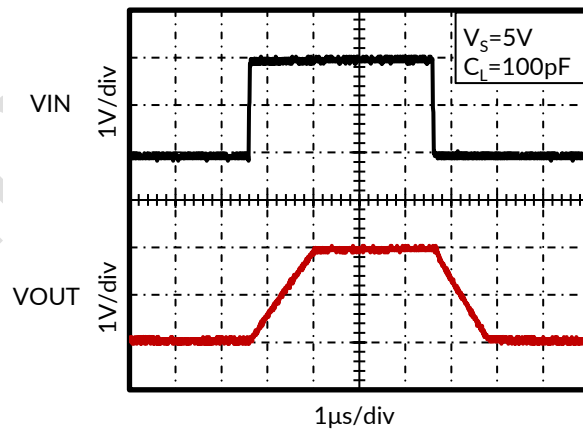

Figure 16. Large Signal Step Response

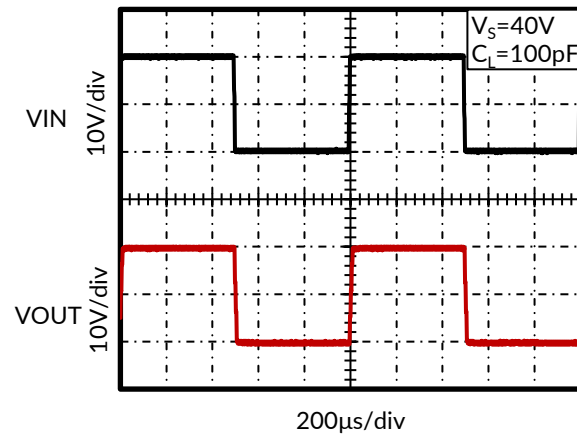

Figure 17. Large Signal Step Response

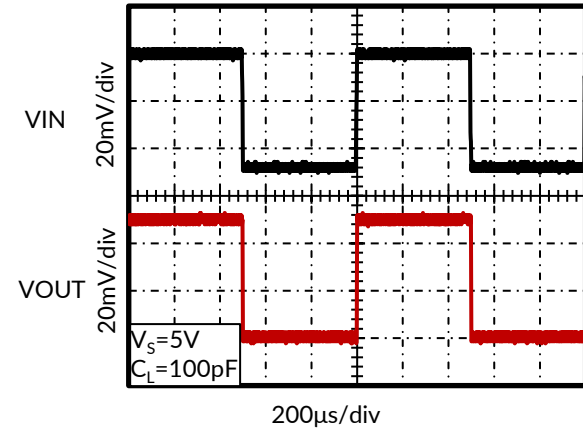

Figure 18. Small Signal Step Response

Typical Characteristics

NOTE: The graphs and tables provided following this note are a statistical summary based on a limited number of samples and are provided for informational purposes only.

At $T_A = +25^\circ\text{C}$, $V_S = \pm 20\text{V}$, $V_{CM} = V_S/2$, $R_L = 10\text{k}\Omega$, unless otherwise specified.

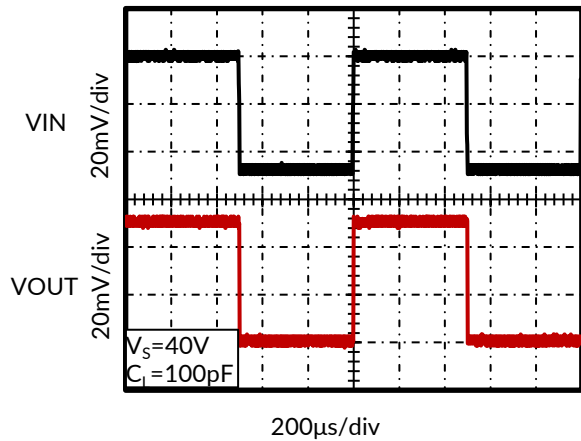

Figure 19. Small Signal Step Response

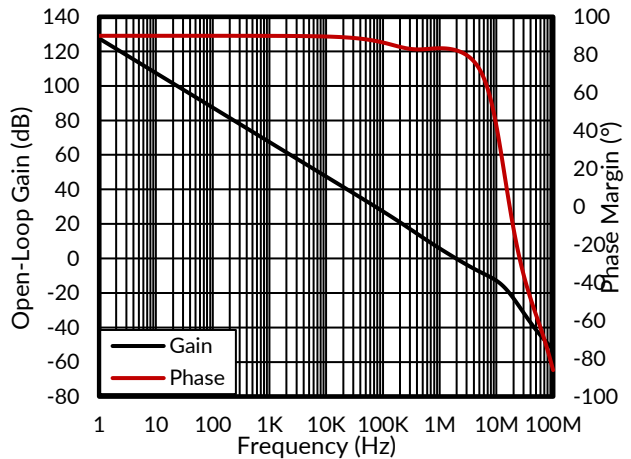

Figure 20. Open-Loop Gain and Phase vs Frequency

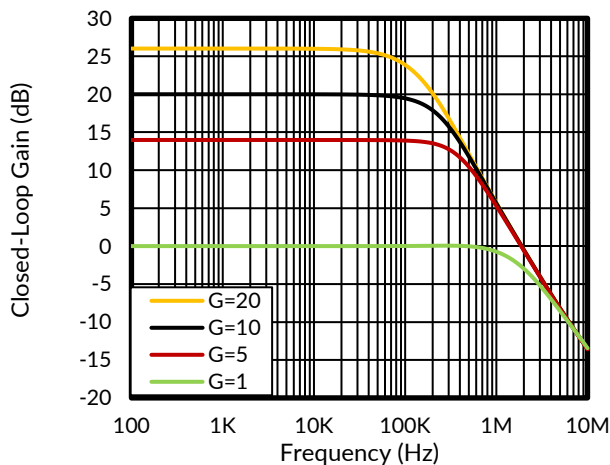

Figure 21. Closed-Loop Gain vs Frequency

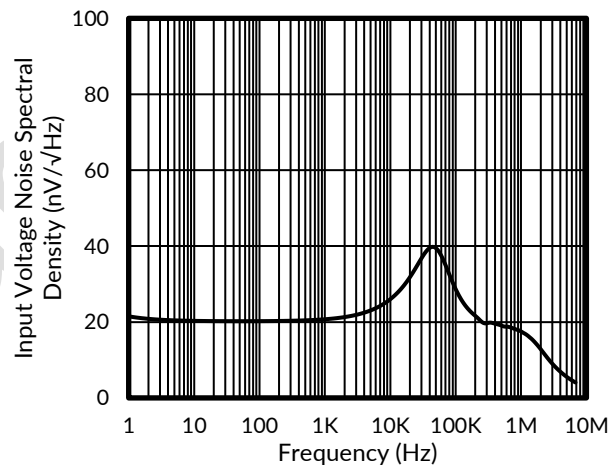

Figure 22. Input Voltage Noise Spectral Density vs Frequency

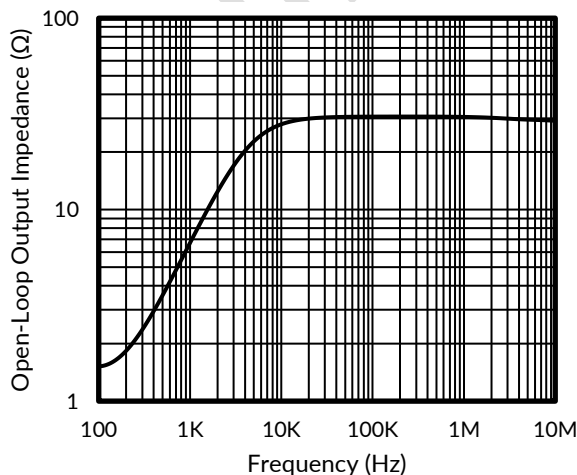
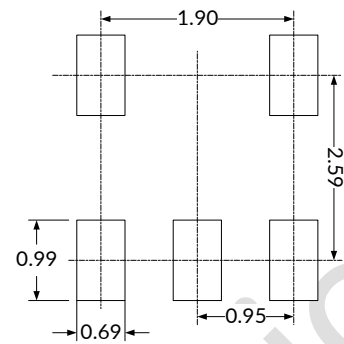
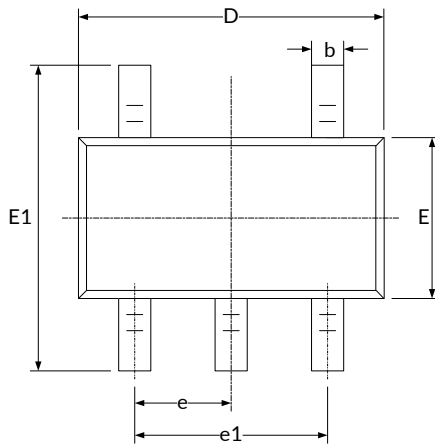
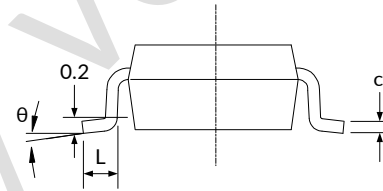
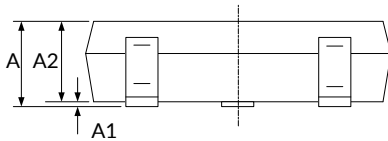

Figure 23. Open-Loop Output Impedance vs Frequency

8 PACKAGE OUTLINE DIMENSIONS

SOT23-5⁽³⁾

RECOMMENDED LAND PATTERN (Unit: mm)

Symbol	Dimensions In Millimeters		Dimensions In Inches	
	Min	Max	Min	Max
A ⁽¹⁾	1.050	1.250	0.041	0.049
A1	0.000	0.100	0.000	0.004
A2	1.050	1.150	0.041	0.045
b	0.300	0.500	0.012	0.020
c	0.100	0.200	0.004	0.008
D ⁽¹⁾	2.820	3.020	0.111	0.119
E ⁽¹⁾	1.500	1.700	0.059	0.067
E1	2.650	2.950	0.104	0.116
e	0.950(BSC) ⁽²⁾		0.037(BSC) ⁽²⁾	
e1	1.800	2.000	0.071	0.079
L	0.300	0.600	0.012	0.024
θ	0°	8°	0°	8°

NOTE:

1. Plastic or metal protrusions of 0.15mm maximum per side are not included.
2. BSC (Basic Spacing between Centers), "Basic" spacing is nominal.
3. This drawing is subject to change without notice.

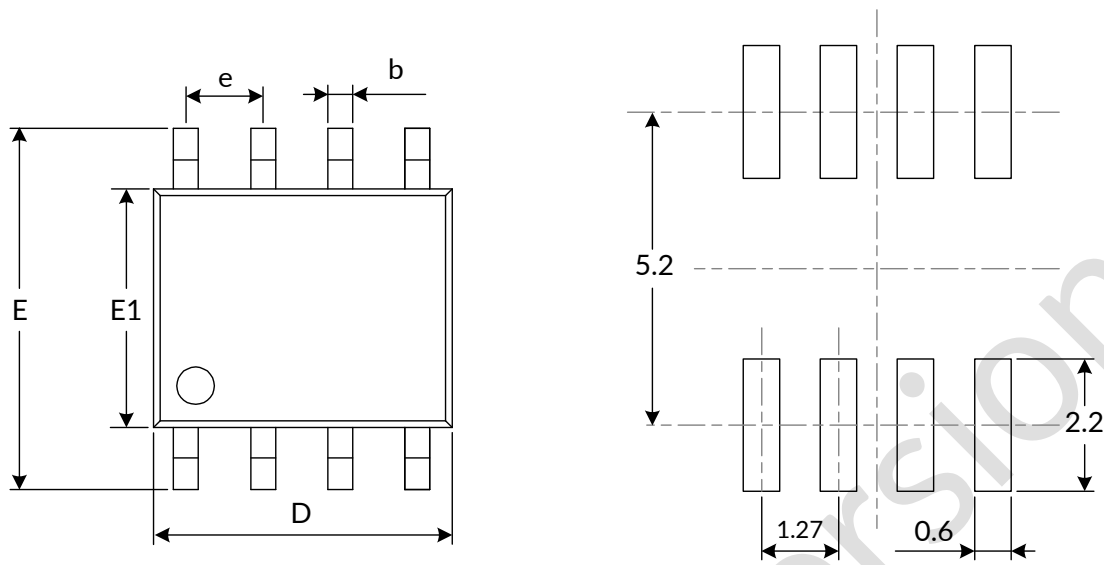
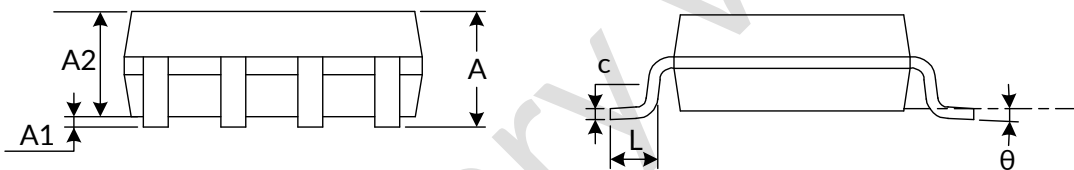
SOP8⁽³⁾

RECOMMENDED LAND PATTERN (Unit: mm)

Symbol	Dimensions In Millimeters		Dimensions In Inches	
	Min	Max	Min	Max
A ⁽¹⁾	1.350	1.750	0.053	0.069
A1	0.100	0.250	0.004	0.010
A2	1.350	1.550	0.053	0.061
b	0.330	0.510	0.013	0.020
c	0.170	0.250	0.007	0.010
D ⁽¹⁾	4.800	5.000	0.189	0.197
e	1.270(BSC) ⁽²⁾		0.050(BSC) ⁽²⁾	
E	5.800	6.200	0.228	0.244
E1 ⁽¹⁾	3.800	4.000	0.150	0.157
L	0.400	1.270	0.016	0.050
θ	0°	8°	0°	8°

NOTE:

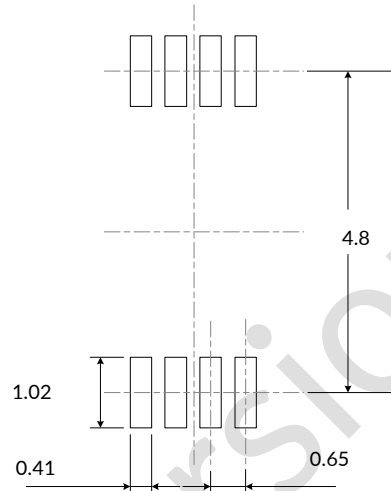
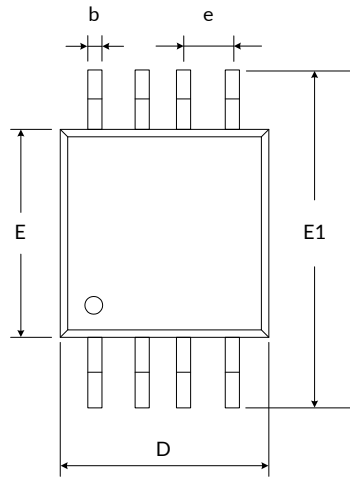
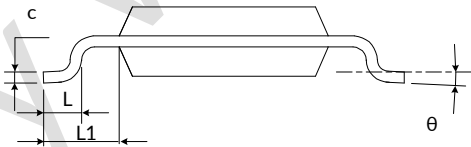
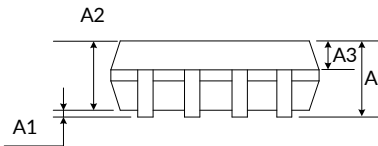
1. Plastic or metal protrusions of 0.15mm maximum per side are not included.
2. BSC (Basic Spacing between Centers), "Basic" spacing is nominal.
3. This drawing is subject to change without notice.

MSOP8 (4)

RECOMMENDED LAND PATTERN (Unit: mm)

Symbol	Dimensions In Millimeters		Dimensions In Inches	
	Min	Max	Min	Max
A ⁽¹⁾		1.100		0.043
A1	0.050	0.150	0.002	0.006
A2	0.750	0.950	0.030	0.037
A3	0.300	0.400	0.012	0.016
b	0.280	0.360	0.011	0.014
c	0.150	0.190	0.006	0.007
D ⁽¹⁾	2.900	3.100	0.114	0.122
e	0.650(BSC) ⁽²⁾		0.026(BSC) ⁽²⁾	
E ⁽¹⁾	2.900	3.100	0.114	0.122
E1	4.700	5.100	0.185	0.200
L	0.400	0.700	0.016	0.027
L1	0.950(REF) ⁽³⁾		0.037(REF) ⁽³⁾	
θ	0°	8°	0°	8°

NOTE:

1. Plastic or metal protrusions of 0.15mm maximum per side are not included.
2. BSC (Basic Spacing between Centers), "Basic" spacing is nominal.
3. REF is the abbreviation for Reference.
4. This drawing is subject to change without notice.

9 TAPE AND REEL INFORMATION

REEL DIMENSIONS

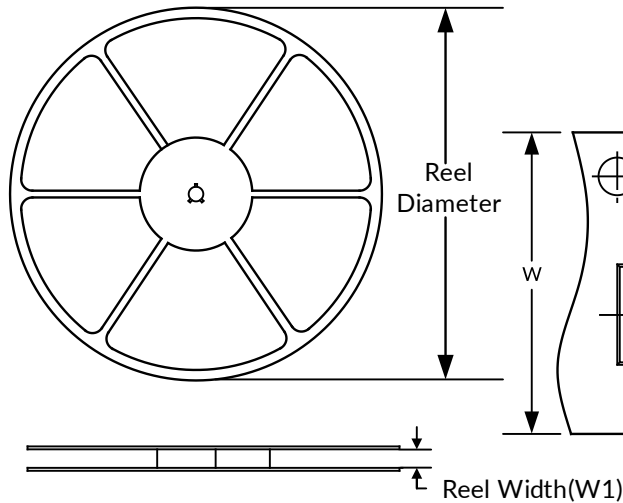

TAPE DIMENSION

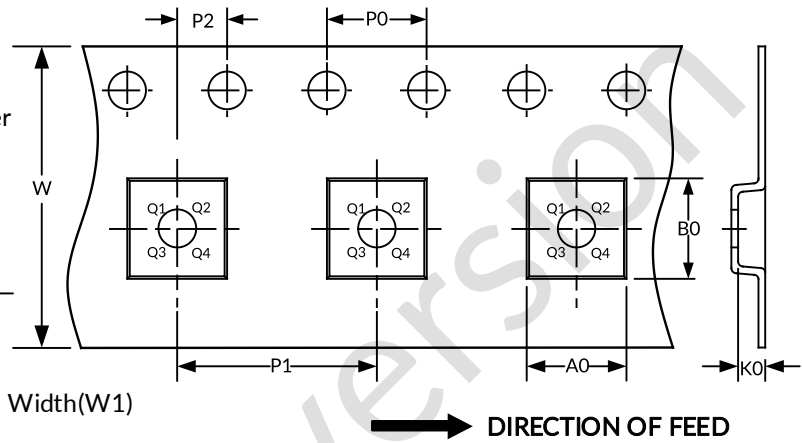

NOTE: The picture is only for reference. Please make the object as the standard.

KEY PARAMETER LIST OF TAPE AND REEL

Package Type	Reel Diameter	Reel Width (mm)	A0 (mm)	B0 (mm)	K0 (mm)	P0 (mm)	P1 (mm)	P2 (mm)	W (mm)	Pin1 Quadrant
SOT23-5	7"	9.5	3.20	3.20	1.40	4.0	4.0	2.0	8.0	Q3
SOP8	13"	12.4	6.40	5.40	2.10	4.0	8.0	2.0	12.0	Q1
MSOP8	13"	12.4	5.20	3.30	1.50	4.0	8.0	2.0	12.0	Q1

NOTE:

1. All dimensions are nominal.
2. Plastic or metal protrusions of 0.15mm maximum per side are not included.

IMPORTANT NOTICE AND DISCLAIMER

Jiangsu Runic Technology Co., Ltd. will accurately and reliably provide technical and reliability data (including data sheets), design resources (including reference designs), application or other design advice, WEB tools, safety information and other resources, without warranty of any defect, and will not make any express or implied warranty, including but not limited to the warranty of merchantability Implied warranty that it is suitable for a specific purpose or does not infringe the intellectual property rights of any third party.

These resources are intended for skilled developers designing with Runic products You will be solely responsible for: (1) Selecting the appropriate products for your application; (2) Designing, validating and testing your application; (3) Ensuring your application meets applicable standards and any other safety, security or other requirements; (4) Runic and the Runic logo are registered trademarks of Runic Incorporated. All trademarks are the property of their respective owners; (5) For change details, review the revision history included in any revised document. The resources are subject to change without notice. Our company will not be liable for the use of this product and the infringement of patents or third-party intellectual property rights due to its use.

Preliminary version