

8-Bit Parallel-in, Serial-out Shift Register

1 FEATURES

- 8-bit parallel-in, serial-out shift
- Power-Supply Range: 2V to 5.5V
- High-current output drive $\pm 10\text{mA}$ at 5.5V
- Low Power Consumption: $8\mu\text{A}(\text{Max})$
- Low Input Current: $1\mu\text{A}(\text{Max})$
- Gated Serial Data Input
- Asynchronous Master Reset
- Extended Temperature: -40°C to 125°C

2 APPLICATIONS

- Video Display Systems
- Programable Logic Controllers
- Enterprise and Communications
- Industrial
- Appliances
- LED Displays
- Output Expander

3 DESCRIPTIONS

The RS165T is 8-bit serial or parallel-in/serial-out shift registers. The device features a serial data input (SER), eight parallel data inputs (D0 to D7) and two complementary serial outputs (Q7 and $\overline{Q7}$). When the parallel load input ($\overline{\text{PL}}$) is Low the data from D0 to D7 is loaded into the shift register asynchronously. When $\overline{\text{PL}}$ is High data enters the register serially at SER. When the clock enable input ($\overline{\text{CE}}$) is Low data is shifted on the Low-to-High transitions of the CLK input. A High on $\overline{\text{CE}}$ will disable the CLK input. Inputs are overvoltage tolerant to 15 V. This enables the device to be used in High-to-Low level shifting applications.

Device Information ⁽¹⁾

PART NUMBER	PACKAGE	BODY SIZE (NOM)
RS165T	TSSOP16	5.00mm×4.40mm
	SOP16	9.90mm×3.90mm

(1) For all available packages, see the orderable addendum at the end of the data sheet.

4 FUNCTIONAL BLOCK DIAGRAM

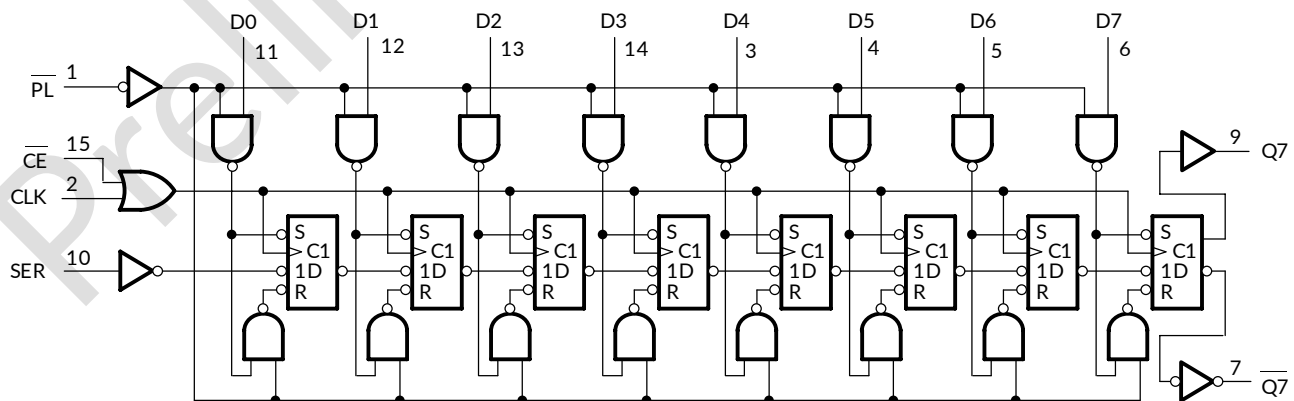

Table of Contents

1 FEATURES	1
2 APPLICATIONS	1
3 DESCRIPTIONS	1
4 FUNCTIONAL BLOCK DIAGRAM	1
5 REVISION HISTORY	3
6 PACKAGE/ORDERING INFORMATION ⁽¹⁾	4
7 PIN CONFIGURATIONS	5
8 FUNCTIONAL TABLE	6
8.1 TIMING DIAGRAM	6
9 SPECIFICATIONS	7
9.1 Absolute Maximum Ratings	7
9.2 ESD Ratings	7
9.3 Recommended Operating Conditions	8
9.4 Electrical Characteristics	8
9.5 Switching Characteristics	9
9.6 Operating Characteristics	10
10 PARAMETER MEASUREMENT INFORMATION	11
11 PACKAGE OUTLINE DIMENSIONS	14
12 TAPE AND REEL INFORMATION	16

5 REVISION HISTORY

Note: Page numbers for previous revisions may differ from page numbers in the current version.

VERSION	Change Date	Change Item
A.0	2025/11/26	Preliminary version completed

Preliminary version

6 PACKAGE/ORDERING INFORMATION ⁽¹⁾

PRODUCT	ORDERING NUMBER	TEMPERATURE RANGE	PACKAGE LEAD	PACKAGE MARKING ⁽²⁾	MSL ⁽³⁾	PACKAGE OPTION
RS165T	RS165TXTSS16	-40°C ~125°C	TSSOP16	RS165T	MSL3	Tape and Reel,4000
	RS165TXS16	-40°C ~125°C	SOP16	RS165T	MSL3	Tape and Reel,4000

NOTE:

- (1) This information is the most current data available for the designated devices. This data is subject to change without notice and revision of this document. For browser-based versions of this data sheet, refer to the right-hand navigation.
- (2) There may be additional marking, which relates to the lot trace code information (data code and vendor code), the logo or the environmental category on the device.
- (3) Runic classify the MSL level with using the common preconditioning setting in our assembly factory conforming to the JEDEC industrial standard J-STD-20F, Please align with Runic if your end application is quite critical to the preconditioning setting or if you have special requirement.

Preliminary version

7 PIN CONFIGURATIONS

(TOP VIEW)

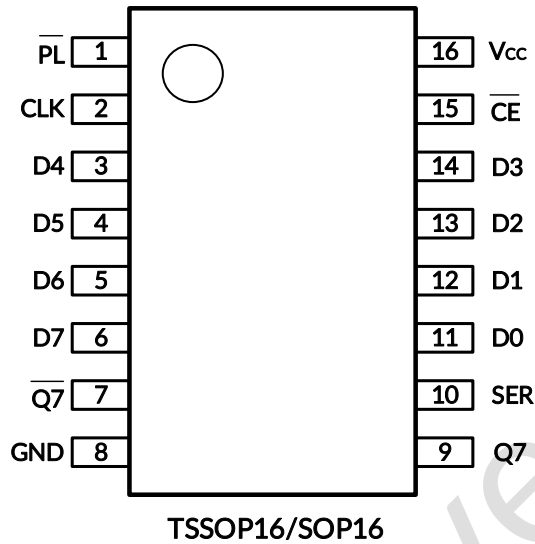

PIN DESCRIPTION

PIN	NAME	TYPE ⁽¹⁾	FUNCTION
TSSOP16/SOP16			
1	\overline{PL}	-	Asynchronous parallel load input (active Low)
2	CLK	I	Clock input (Low-to-High, edge-triggered)
11,12,13,14,3,4,5,6	D0~D7	O	Parallel data inputs
7	$\overline{Q7}$	O	Complementary output from the last stage
8	GND	G	Ground.
9	Q7	O	Serial output from the last stage
10	SER	I	Serial data input
15	\overline{CE}	I	Clock enable input (active Low)
16	V _{cc}	P	Supply voltage

(1) I=input, O=output, P=power, G=Ground.

8 FUNCTIONAL TABLE

Operating modes	Input					Qn register		Output	
	$\overline{\text{PL}}$	$\overline{\text{CE}}$	CLK	SER	D0 to D7	Q0	Q1 to Q6	Q7	$\overline{\text{Q7}}$
Parallel load	L	X	X	X	L	L	L to L	L	H
	L	X	X	X	H	H	H to H	H	L
Serial shift	H	L	↑	l	X	L	q0 to q5	q6	$\overline{\text{q6}}$
	H	L	↑	h	X	H	q0 to q5	q6	$\overline{\text{q6}}$
	H	↑	L	l	X	L	q0 to q5	q6	$\overline{\text{q6}}$
	H	↑	L	h	X	H	q0 to q5	q6	$\overline{\text{q6}}$
Hold "Do nothing"	H	H	X	X	X	q0	q1 to q6	q7	$\overline{\text{q7}}$
	H	X	H	X	X	q0	q1 to q6	q7	$\overline{\text{q7}}$

H = High voltage level;

h = High voltage level one set-up time prior to the Low-to-High clock transition;

L = Low voltage level;

l = Low voltage level one set-up time prior to the Low-to-High clock transition;

q = Lower case letters indicate the state of the referenced input one set-up time prior to the Low-to-High clock transition;

↑ = Low-to-High clock transition;

X = don't care;

8.1 TIMING DIAGRAM

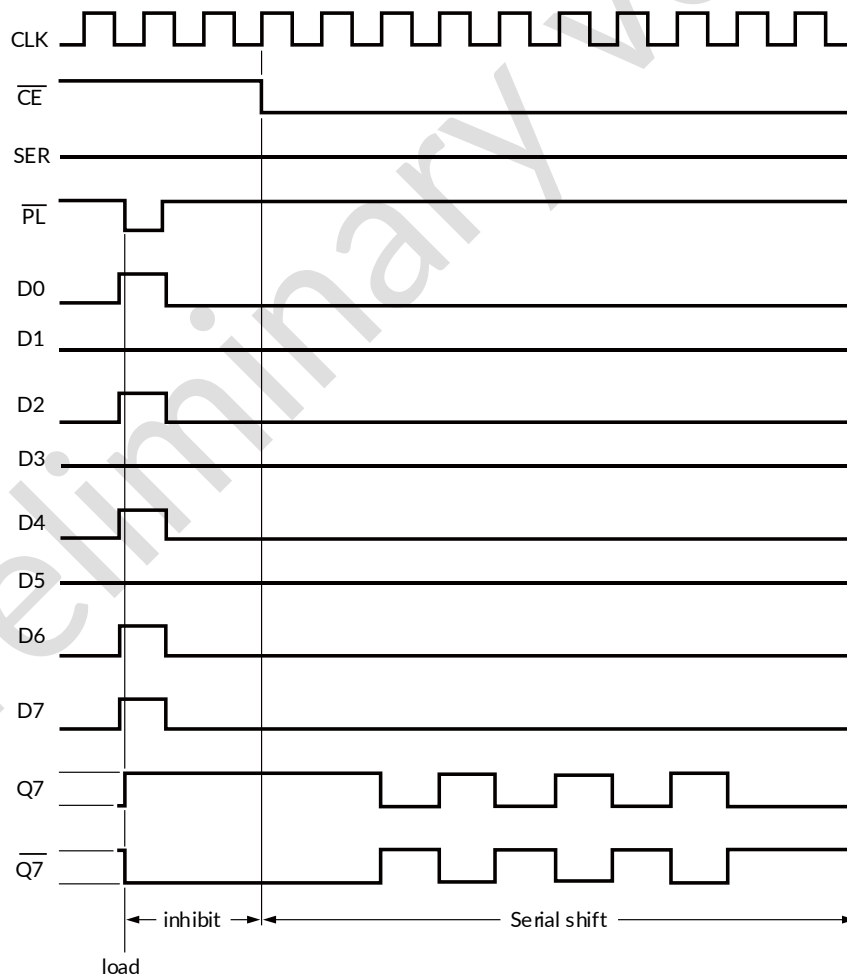

9 SPECIFICATIONS

9.1 Absolute Maximum Ratings

Over operating free-air temperature range (unless otherwise noted) ⁽¹⁾

SYMBOL	PARAMETER		MIN	MAX	UNIT
V _{CC}	Supply Voltage Range		-0.5	6.5	V
V _I	Input Voltage Range ⁽²⁾		-0.5	6.5	V
V _O	Voltage range applied to any output in the high-impedance or power-off state ⁽²⁾		-0.5	6.5	V
I _{IK}	Input Clamp Current	V _I <0		-50	mA
I _{OK}	Output Clamp Current	V _O <0		-50	mA
I _O	Continuous Output Current			±25	mA
I _{CC}	Continuous Current Through V _{CC} or GND			±50	mA
θ _{JA}	Package Thermal Impedance ⁽³⁾	TSSOP16		108	°C/W
		SOP16		76	
T _J	Junction Temperature ⁽⁴⁾			150	°C
T _{stg}	Storage Temperature		-65	150	

(1) Stresses beyond those listed under Absolute Maximum Ratings may cause permanent damage to the device. These are stress ratings only, which do not imply functional operation of the device at these or any other conditions beyond those indicated under Recommended Operating Conditions. Exposure to absolute-maximum-rated conditions for extended periods may affect device reliability.

(2) The input and output negative-voltage ratings may be exceeded if the input and output current ratings are observed.

(3) The package thermal impedance is calculated in accordance with JESD-51.

(4) The maximum power dissipation is a function of T_{J(MAX)}, R_{θJA}, and T_A. The maximum allowable power dissipation at any ambient temperature is P_D = (T_{J(MAX)} - T_A) / R_{θJA}. All numbers apply for packages soldered directly onto a PCB.

9.2 ESD Ratings

The following ESD information is provided for handling of ESD-sensitive devices in an ESD protected area only.

			VALUE	UNIT
V _(ESD)	Electrostatic discharge	Human-Body Model (HBM), MIL-STD-883K METHOD 3015.9	±2000	V
		Charged-Device Model (CDM), ANSI/ESDA/JEDEC JS-002-2018	±1000	
		Machine Model (MM), JESD22-A115C (2010)	±200	



ESD SENSITIVITY CAUTION

ESD damage can range from subtle performance degradation to complete device failure. Precision integrated circuits may be more susceptible to damage because very small parametric changes could cause the device not to meet its published specifications.

9.3 Recommended Operating Conditions

Voltages are reference to GND (0V).

PARAMETER		V _{CC}	MIN	TYP	MAX	UNIT
Supply voltage	V _{CC}		2		5.5	V
Input voltage	V _I		0		V _{CC}	V
Output voltage	V _O		0		V _{CC}	V
Input transition rise or fall rate	$\Delta t/\Delta v$	2V to 5.5V			5	ns/V
Operating free-air temperature	T _A		-40		125	°C

9.4 Electrical Characteristics

over recommended operating free-air temperature range (unless otherwise noted)

PARAMETER	SYMBOL	TEST CONDITIONS	V _{CC}	TEMP	MIN ⁽¹⁾	TYP ⁽²⁾	MAX ⁽¹⁾	UNIT
High-Level Input Voltage	V _{IH}	V _{CC} =2V		FULL	1			V
		V _{CC} =3.3V			1.5			
		V _{CC} =4.5V to 5.5V			2			
Low-Level Input Voltage	V _{IL}	V _{CC} =2V		FULL			0.3	V
		V _{CC} =3.3V					0.55	
		V _{CC} =4.5V to 5.5V					0.8	
High-Level Output Voltage	V _{OH}	I _O = -100 μA	2V to 5.5V	FULL	V _{CC} -0.1			V
		I _O = -4 mA	3V		1.2			
		I _O = -8 mA	3.3V		1.9			
		I _O = -10 mA	5.5V		3.8			
Low-Level Output Voltage	V _{OL}	I _O = 100 μA	2V to 5.5V	FULL			0.1	V
		I _O = 4 mA	3V				0.45	
		I _O = 8 mA	3.3V				0.4	
		I _O = 10 mA	5.5V				0.55	
Input Leakage Current	I _I	V _I =5.5V or GND	0V to 5.5V	25°C		±0.1	±1	μA
				FULL			±5	
Supply Current	I _{CC}	V _I =5.5V or GND, I _O =0	2V to 5.5V	25°C		0.1	8	μA
				FULL			160	
Input Capacitance	C _I	f=1MHz	3.3V	25°C		3.7		pF

(1) Limits are 100% production tested at 25°C. Limits over the operating temperature range are ensured through correlations using statistical quality control (SQC) method.

(2) Typical values represent the most likely parametric norm as determined at the time of characterization. Actual typical values may vary over time and will also depend on the application and configuration.

9.5 Switching Characteristics

SYMBOL	PARAMETER	TEST CONDITIONS	25°C ⁽¹⁾			-40°C to 125°C ⁽¹⁾			UNIT	
			MIN	TYP	MAX	MIN	TYP	MAX		
$t_{pd}^{(2)}$	Propagation delay	CLK or \overline{CE} to Q7 or $\overline{Q7}$							ns	
		$V_{CC}=2V\pm 0.15V$		28				42		
		$V_{CC}=3.3V\pm 0.3V$		10				15		
				$V_{CC}=5V\pm 0.5V$		4			6	
		D7 to Q7 or $\overline{Q7}$							ns	
		$V_{CC}=2V\pm 0.15V$		38				57		
		$V_{CC}=3.3V\pm 0.3V$		21				32		
				$V_{CC}=5V\pm 0.5V$		17			26	
		\overline{PL} to Q7 or $\overline{Q7}$							ns	
		$V_{CC}=2V\pm 0.15V$		38				57		
		$V_{CC}=3.3V\pm 0.3V$		19				29		
		$V_{CC}=5V\pm 0.5V$		15				23		
$t_t^{(3)}$	transition time	Q7 or $\overline{Q7}$ output							ns	
		$V_{CC}=2V\pm 0.15V$		5				8		
		$V_{CC}=3.3V\pm 0.3V$		3				5		
		$V_{CC}=5V\pm 0.5V$		2				3		
t_h	Hold width	SER to CLK or \overline{CE}							ns	
		$V_{CC}=2V\pm 0.15V$		-12		5	3			
		$V_{CC}=3.3V\pm 0.3V$		-5		5	3			
		$V_{CC}=5V\pm 0.5V$		-3		5	3			
		Dn to \overline{PL}							ns	
		$V_{CC}=2V\pm 0.15V$		-5		5	3			
$V_{CC}=3.3V\pm 0.3V$		-1.5		5	3					
		$V_{CC}=5V\pm 0.5V$		-1		5	3			
t_{su}	Set-up time	SER to CLK or \overline{CE}							ns	
		$V_{CC}=2V\pm 0.15V$		11		16.5				
		$V_{CC}=3.3V\pm 0.3V$		5		7.5				
		$V_{CC}=5V\pm 0.5V$		3		4.5				
		Dn to \overline{PL}							ns	
		$V_{CC}=2V\pm 0.15V$		5		7.5				
$V_{CC}=3.3V\pm 0.3V$		1.5		2.5						
		$V_{CC}=5V\pm 0.5V$		1		1.5				
t_{rec}	Recovery time	\overline{PL} to CLK or \overline{CE}							ns	
		$V_{CC}=2V\pm 0.15V$		5		15				
		$V_{CC}=3.3V\pm 0.3V$		1		3				
		$V_{CC}=5V\pm 0.5V$		1		3				
f_{max}	Maximum frequency	For CLK CL=15pF							MHz	
		$V_{CC}=2V\pm 0.15V$		4		2				
		$V_{CC}=3.3V\pm 0.3V$		20		10				
		$V_{CC}=5V\pm 0.5V$		30		15				

t _w	Pulse width	CLK							
		V _{CC} =2V±0.15V		30		80			ns
		V _{CC} =3.3V±0.3V		20		40			
		V _{CC} =5V±0.5V		20		22			
		PL							
		V _{CC} =2V±0.15V		30		80			ns
V _{CC} =3.3V±0.3V		20		40					
V _{CC} =5V±0.5V		20		22					

NOTE:

- (1) This parameter is ensured by design and/or characterization and is not tested in production.
- (2) t_{pd} is the same as t_{PHL} and t_{PLH}.
- (3) t_t is the same as t_{THL} and t_{TLH}.

9.6 Operating Characteristics

T_A=25°C

PARAMETER	TEST CONDITIONS	V _{CC} =3.3V	V _{CC} =5V	UNIT
		TYP	TYP	
C _{pd} ⁽¹⁾	C _L =0, f=10MHz	11	17	pF

- (1) Power dissipation capacitance per transceiver.

10 PARAMETER MEASUREMENT INFORMATION

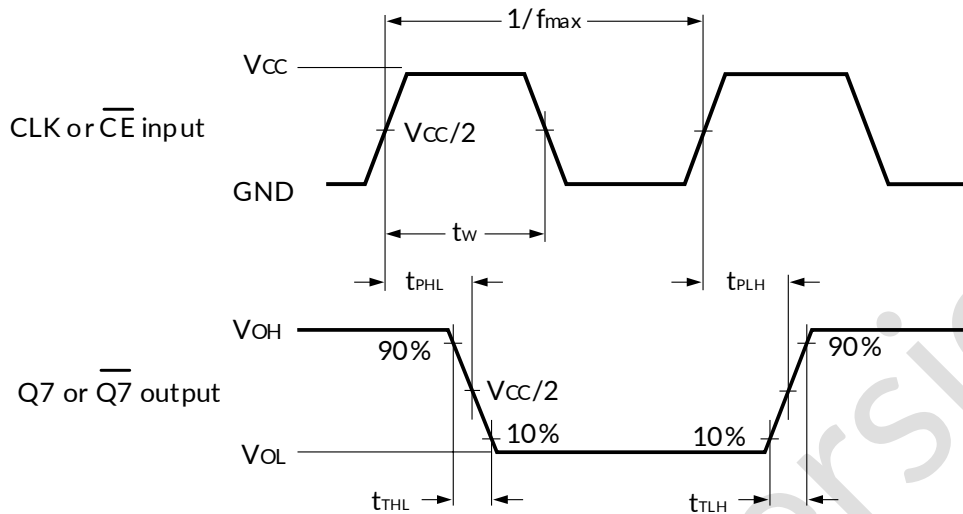

V_{OL} and V_{OH} are typical voltage output levels that occur with the output load.

Figure 1. The clock (CLK) or clock enable (\overline{CE}) to output (Q7 or $\overline{Q7}$) propagation delays, the clock pulse width, the maximum clock frequency and the output transition times

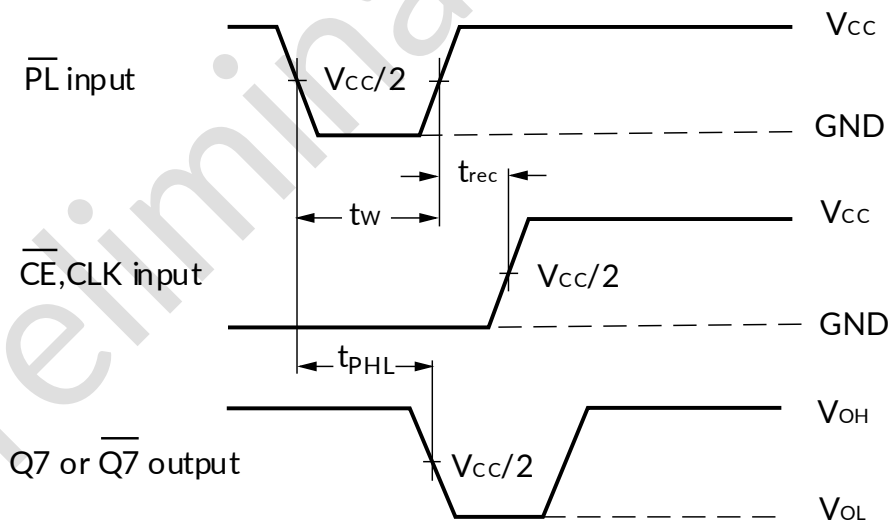

V_{OL} and V_{OH} are typical voltage output levels that occur with the output load.

Figure 2. The parallel load (\overline{PL}) pulse width, the parallel load to output (Q7 or $\overline{Q7}$) propagation delays, the parallel load to clock (CLK) and clock enable (\overline{CE}) recovery time

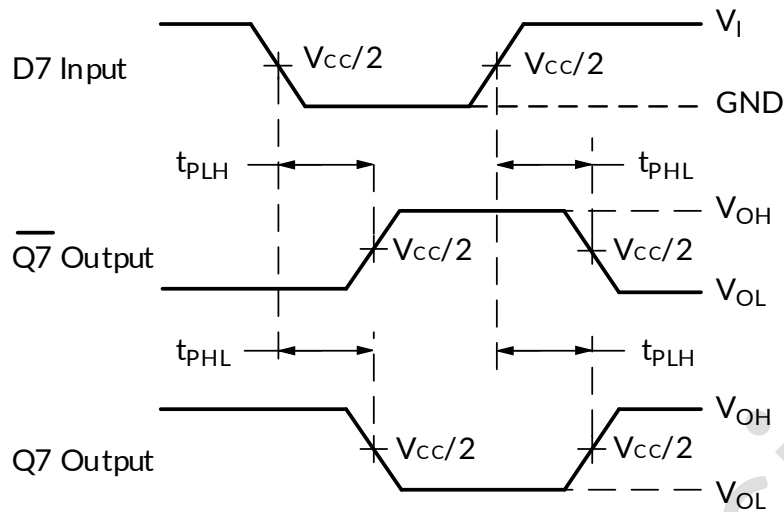

V_{OL} and V_{OH} are typical voltage output levels that occur with the output load.

Figure 3. The data input (D7) to output (Q7 or $\overline{Q7}$) propagation delays when \overline{PL} is LOW

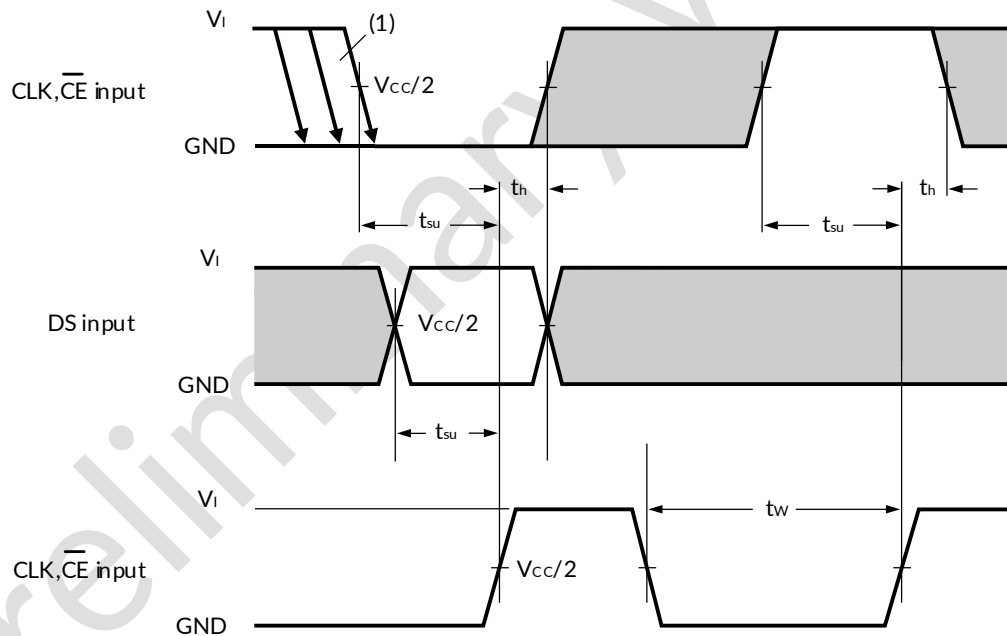

The shaded areas indicate when the input is permitted to change for predictable output performance.

V_{OL} and V_{OH} are typical voltage output levels that occur with the output load.

(1) \overline{CE} may change only from HIGH-to-LOW while CLK is LOW, see Section 1.

Figure 4. The set-up and hold times from the serial data input (DS) to the clock (CLK) and clock enable (\overline{CE}) inputs, from the clock enable input (\overline{CE}) to the clock input (CLK) and from the clock input (CLK) to the clock enable input (\overline{CE})

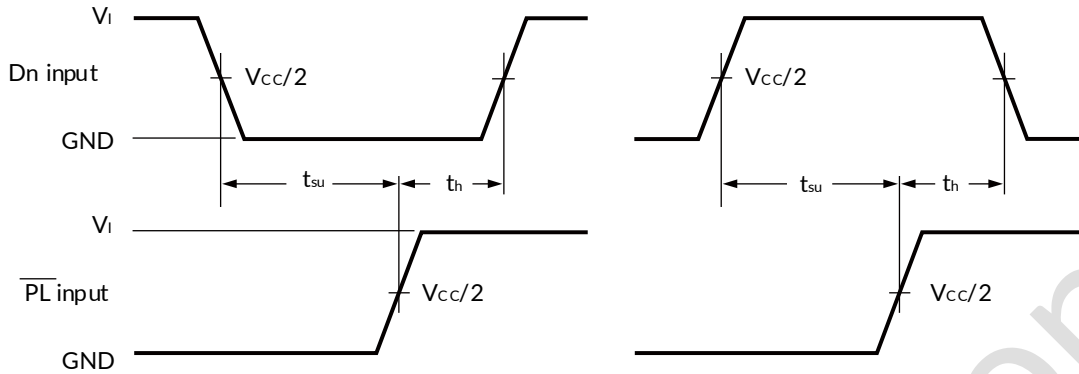

V_{OL} and V_{OH} are typical voltage output levels that occur with the output load.

Figure 5. The set-up and hold times from the data inputs (Dn) to the parallel load input (\overline{PL})

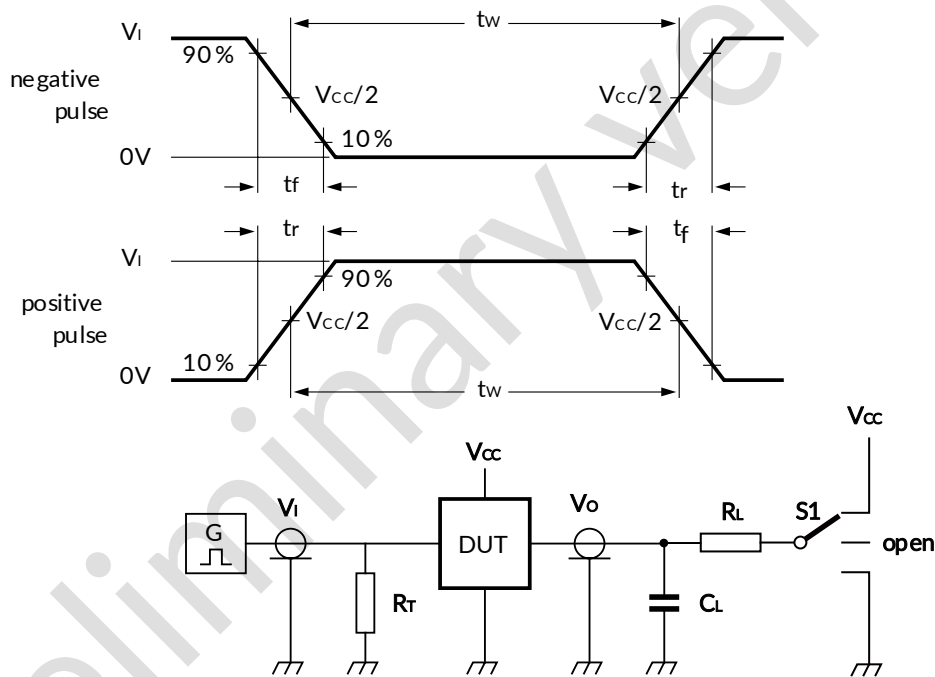

Test data is given in Table 1.

Definitions test circuit:

R_T = termination resistance should be equal to output impedance Z_o of the pulse generator.

C_L = load capacitance including jig and probe capacitance.

R_L = Load resistance.

S1 = Test selection switch.

Figure 6. Test circuit for measuring switching times

Table 1. Test data

S1 position	Input		Load	
t_{PHL}/t_{PLH}	V_i	t_r, t_f	C_L	R_L
open	V_{CC}	6ns	15pF, 50pF	1k Ω

11 PACKAGE OUTLINE DIMENSIONS

SOP16⁽³⁾

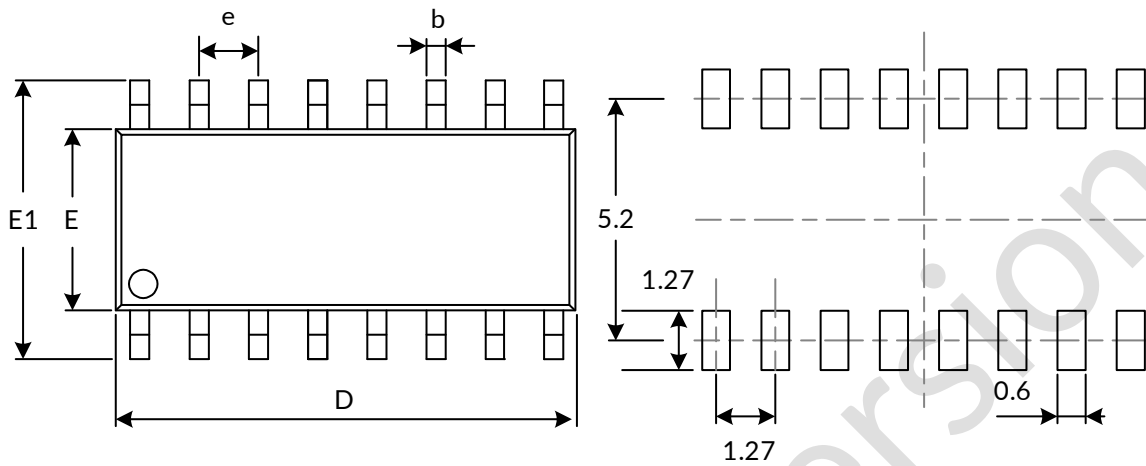
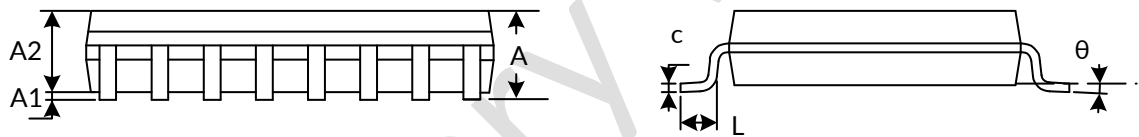
RECOMMENDED LAND PATTERN (Unit: mm)

Symbol	Dimensions In Millimeters		Dimensions In Inches	
	Min	Max	Min	Max
A ⁽¹⁾		1.750		0.069
A1	0.100	0.225	0.004	0.009
A2	1.300	1.500	0.051	0.059
b	0.390	0.470	0.015	0.019
c	0.200	0.240	0.007	0.010
D ⁽¹⁾	9.800	10.00	0.386	0.394
E ⁽¹⁾	3.800	4.000	0.150	0.157
E1	5.800	6.200	0.228	0.244
e	1.270 (BSC) ⁽²⁾		0.050 (BSC) ⁽²⁾	
L	0.500	0.800	0.020	0.032
θ	0°	8°	0°	8°

NOTE:

1. Plastic or metal protrusions of 0.15mm maximum per side are not included.
2. BSC (Basic Spacing between Centers), "Basic" spacing is nominal.
3. This drawing is subject to change without notice.

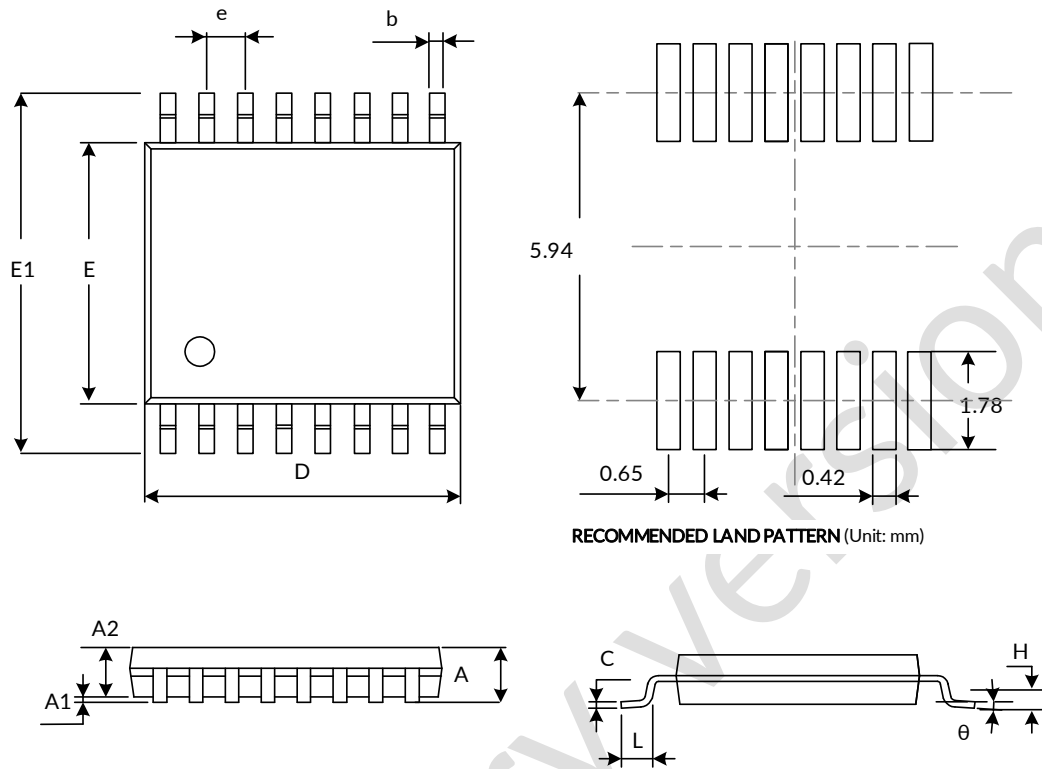
TSSOP16 (3)

RECOMMENDED LAND PATTERN (Unit: mm)

Symbol	Dimensions In Millimeters		Dimensions In Inches	
	Min	Max	Min	Max
A ⁽¹⁾		1.200		0.047
A1	0.050	0.150	0.002	0.006
A2	0.900	1.050	0.035	0.041
b	0.200	0.280	0.007	0.011
c	0.130	0.170	0.005	0.007
D ⁽¹⁾	4.900	5.100	0.193	0.201
E ⁽¹⁾	4.300	4.500	0.169	0.177
E1	6.200	6.600	0.244	0.260
e	0.650(BSC) ⁽²⁾		0.026(BSC) ⁽²⁾	
L	0.450	0.750	0.017	0.030
H	0.250 TYP		0.010 TYP	
θ	0°	8°	0°	8°

NOTE:

1. Plastic or metal protrusions of 0.15mm maximum per side are not included.
2. BSC (Basic Spacing between Centers), "Basic" spacing is nominal.
3. This drawing is subject to change without notice.

12 TAPE AND REEL INFORMATION

REEL DIMENSIONS

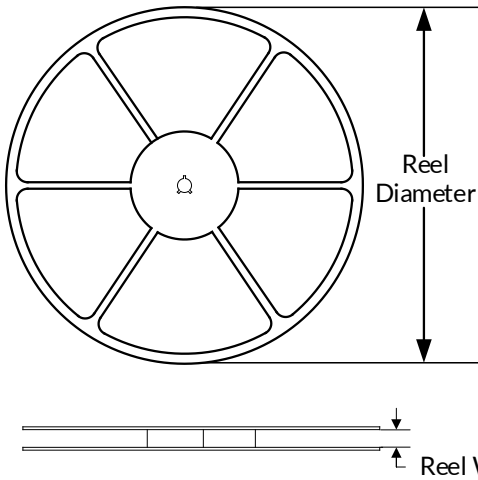

TAPE DIMENSION

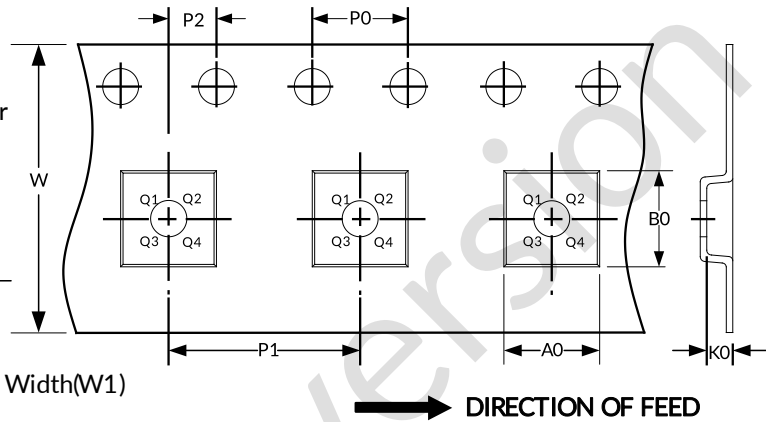

NOTE: The picture is only for reference. Please make the object as the standard.

KEY PARAMETER LIST OF TAPE AND REEL

Package Type	Reel Diameter	Reel Width (mm)	A0 (mm)	B0 (mm)	K0 (mm)	P0 (mm)	P1 (mm)	P2 (mm)	W (mm)	Pin1 Quadrant
SOP16	13"	16.4	6.50	10.30	2.10	4.0	8.0	2.0	16.0	Q1
TSSOP16	13"	12.4	6.90	5.60	1.20	4.0	8.0	2.0	12.0	Q1

NOTE:

1. All dimensions are nominal.
2. Plastic or metal protrusions of 0.15mm maximum per side are not included.

IMPORTANT NOTICE AND DISCLAIMER

Jiangsu Runic Technology Co., Ltd. will accurately and reliably provide technical and reliability data (including data sheets), design resources (including reference designs), application or other design advice, WEB tools, safety information and other resources, without warranty of any defect, and will not make any express or implied warranty, including but not limited to the warranty of merchantability Implied warranty that it is suitable for a specific purpose or does not infringe the intellectual property rights of any third party.

These resources are intended for skilled developers designing with Runic products You will be solely responsible for: (1) Selecting the appropriate products for your application; (2) Designing, validating and testing your application; (3) Ensuring your application meets applicable standards and any other safety, security or other requirements; (4) Runic and the Runic logo are registered trademarks of Runic Incorporated. All trademarks are the property of their respective owners; (5) For change details, review the revision history included in any revised document. The resources are subject to change without notice. Our company will not be liable for the use of this product and the infringement of patents or third-party intellectual property rights due to its use.

Preliminary version